

REV	DESCRIPTION	DESIGN	DATE
A0	Release	吴丹平	2016.11.28

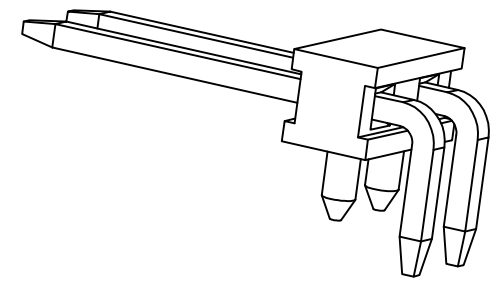
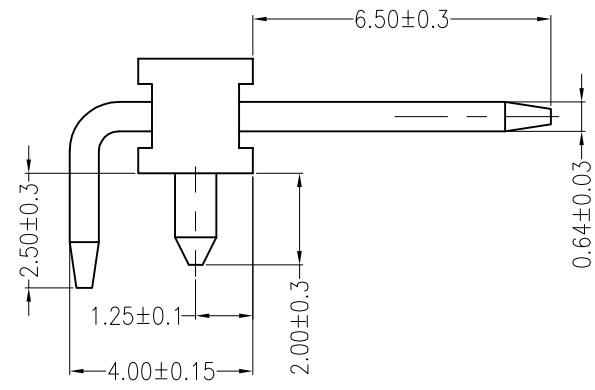
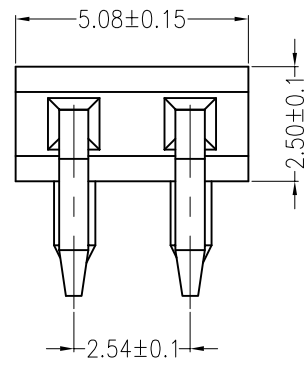

主要技术参数 Main Specifications

- 线 数 (Poles): 02 to 06
- 接触电阻 (Contact resistance): $\leq 20m\Omega$
- 绝缘电阻 (Insulation resistance): $\geq 1000M\Omega$
- 额定电压 (Rated voltage): 125V AC DC
- 额定电流 (Rated current): 1.0A AC DC
- 耐 电压 (Withstand Voltage): 1500V AC/minute
- 温度范围 (Temperature Range): $-40^{\circ}C \sim +120^{\circ}C$

ORDER INFORMATION:

L039A-02-F2MB-P

PART No.		PACKAGING:
No. FOR CIRCUITS:		P=PE
PLASTIC MATERIAL:		PLATING:
F2M=LCP (BEIGE)		B=MATTE Sn

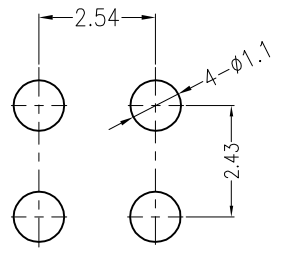
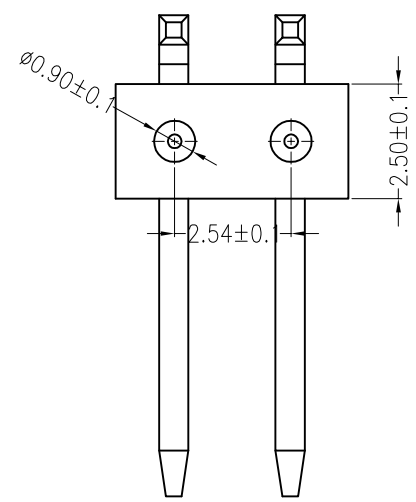

Board Layout

ITEM	COMPONENT	Q'TY	MATERIAL	FINISH
C				
B	CONTACT	2 PCS	Brass	Sn-plated
A	PEDESTAL	1 PCS	LCP	UL 94V-0, COLOR:BEIGE

東莞市高迪電子有限公司 DONG GUAN GAO DI ELECTRONICS CO., LTD		TITLE: -	
		2.54mmPITCH 90°WAFER DIP TYPE	
X.±0.5	X.±5'	USE: CUSTOMER	PART NO.:
.X±0.3	.X±2'		L039A-02-F2MB-P
.XX±0.25	.XX±1'		DWG NO.:
--	--	CHKD: 田 峰	GCCP-0102
UNITS: mm	DR: 吴丹平	SCALE	SHEET
		1 : 1	1 / 1

REV	DESCRIPTION	DESIGN	DATE
A0	Release	吴丹平	2016.04.30

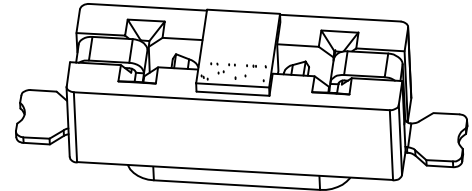
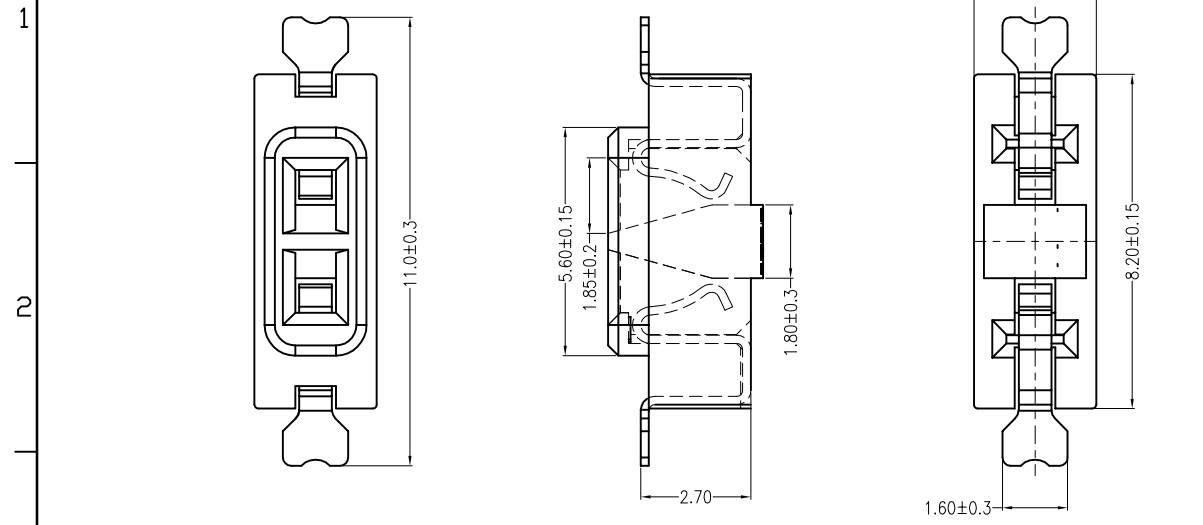

主要技术参数 Main Specifications

- 线 数 (Poles): 02
- 接触电阻 (Contact resistance): $\leq 20m\Omega$
- 绝缘电阻 (Insulation resistance): $\geq 1000M\Omega$
- 额定电压 (Rated voltage): 125V AC DC
- 额定电流 (Rated current): 1.0A AC DC
- 耐 电压 (Withstand Voltage): 1500V AC/minute
- 温度范围 (Temperature Range): $-40^{\circ}C \sim +120^{\circ}C$

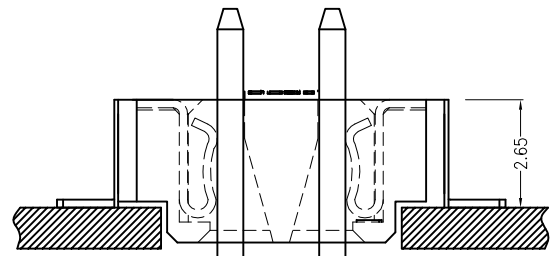
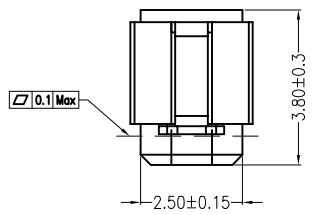

ORDER INFORMATION:

L039Y-02-F2MB-R

PART No. _____	PACKAGING: _____
No. FOR CIRCUITS: _____	P=PE
02	R=REEL
PLASTIC MATERIAL: _____	PLATING: _____
F2M=LCP (BEIGE)	B=MATTE Sn

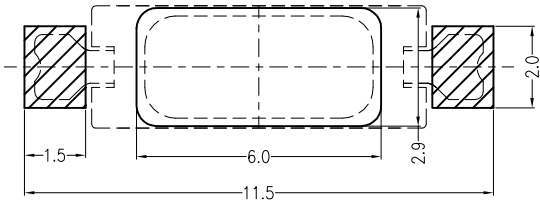

Board Layout
General Tolerance: ± 0.05

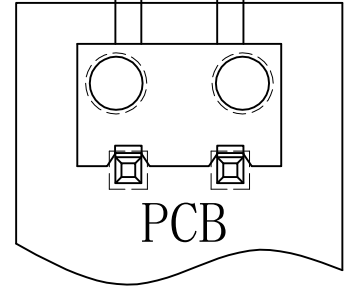

PCB
Assembly Layout

C				
B	CONTACT	2 PCS	PhosphorBronze	MATTE Sn-plated
A	PEDESTAL	1 PCS	LCP	UL 94V-0, COLOR:BEIGE
ITEM	COMPONENT	Q'TY	MATERIAL	FINISH

東莞市高迪電子有限公司
DONG GUAN GAO DI ELECTRONICS CO., LTD

TITLE: -
2.5mmPITCH 180°WAFER SMT TYPE

X.±0.5	X.±5'	USE:	CUSTOMER	PART NO.:	L039Y-02-F2MB-R
.X±0.3	.X±2'	APPD:	邵敬和	DWG NO.:	GCCP-0065
.XX±0.25	.XX±1'	CHKD:	田峰	SCALE	1 : 1
--	--	DR:	吴丹平	SHEET	1 / 1
UNITS: mm					